

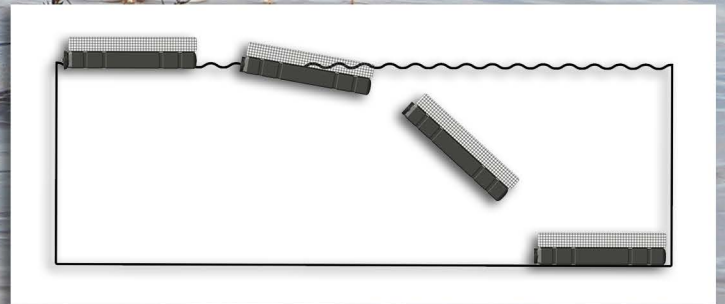

Go Deep
International Inc.

ECO-AQUA™ SUBMERSIBLE OYSTER BAG FLOAT

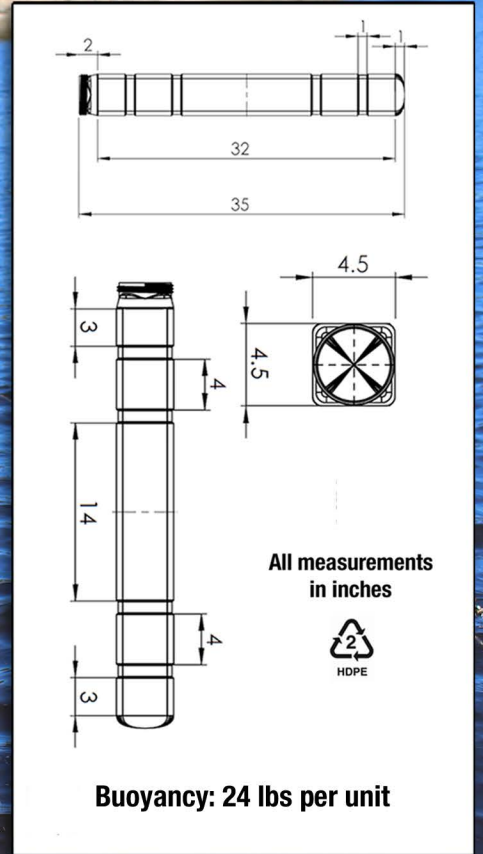

**MADE IN
NORTH AMERICA**

ORDER BY CALLING: 1 (877) 446-3337 (NORTH AMERICA)

01 (506) 633-7850 (INTERNATIONAL)

WWW.GODEEPAQUACULTURE.COM



Go Deep
International Inc.

ECO-AQUA™ SUBMERSIBLE OYSTER BAG FLOAT



Features:

UV Stabilized Virgin Plastic
Built to Growers' Specifications
Compact Design
Secure Buoyancy
Quality Assurance Manufactured

Benefits:

Ideal for Small or Large Farms
Fewer Caps to Store and Transport
Increased Productivity
Easy to Sink
Easy to Float

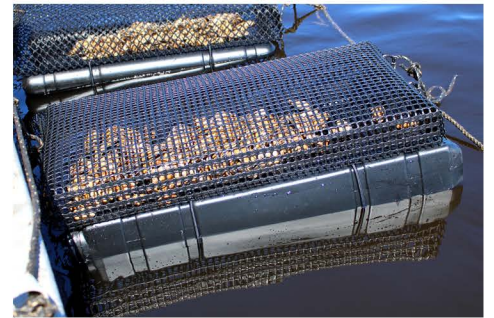

Eco-Aqua™ 11-1C floats mount flush with Go Deep oyster bags, creating a robust growing system. The floats are designed to be attached to the bag which provides oysters with increased food for growth and greater bag height if in the de-fouling position.

The wide-mouthed single cap design allows water to flow quickly into the float. The caps are easily removed and replaced, making the process easy and efficient. Caps can be tightened by hand or by screwdriver.

As part of a long line system, Eco-Aqua™ 11-1C floats provide increased buoyancy over traditional single bag floats. Manufactured from UV stable 100% virgin material, Eco-Aqua™ oyster bag floats have an unmatched longevity with many floats spending 20+ years on the water.



Ask us about our Made in North America oyster bags!

**MADE IN
NORTH AMERICA**

ORDER BY CALLING: 1 (877) 446-3337 (NORTH AMERICA)

01 (506) 633-7850 (INTERNATIONAL)

WWW.GODEEPAQUACULTURE.COM